



Quality • Consistency • Dependability

## Packaging Supplies Catalog



# Challenger<sup>®</sup>

PACKAGING



Corrugated Materials .....	3
Strapping .....	4
Strap Sealing .....	6
Film .....	7
Tape - Specialty .....	8
Tape - Carton Sealing .....	9
Protective Packaging .....	10

**Challenger Packaging** is a leading manufacturer of high-performance packaging solutions engineered to protect, secure, and optimize operational efficiency. From professional-grade strapping tools and durable strapping materials to high-quality films, reliable tapes, protective packaging, and corrugated solutions, we deliver products designed for strength, consistency, and performance.

**Challenger Packaging** maintains a strong commitment to innovation and quality that empowers businesses to package and ship with confidence.



# Corrugated Materials



## Stock Boxes

With over **1,600** stock sizes, we offer single, double, and triple wall boxes to provide the right level of protection for your product. Available in both kraft and white finishes.

### **Custom Sizing & Print Available -**

Contact your sales rep for more information!



## Corrugated Sheets

Available in over **50** standard sizes, our corrugate sheets are offered in single, double, and triple wall construction to match the strength requirements of your application.

### **Custom Sizing Available -**

Contact your sales rep for more information!



## Honeycomb Corrugation

We offer honeycomb corrugation in a wide range of sizes and thicknesses, designed to deliver enhanced cushioning and structural support. Ideal for products that require extra protection, honeycomb corrugation helps absorb impact, distribute weight evenly.



## Single Face Corrugation

Our single face corrugation is available in "A" and "B" flute profiles across a wide variety of widths to meet diverse packaging needs.

**A-flute** (1/4") provides dependable shock absorption and crush resistance.

**B-flute** (1/8") offers a lower profile with increased flexibility.



## Bulk Bins / Gaylords

Bulk bins are available in a variety of sizes, shapes, and board grades to support multiple applications. They help protect large shipment quantities, secure irregularly shaped items during transit, and can be used as scrap receptacles to keep warehouses clean and organized.

# Strapping

## Composite Cord Strap



Part #	Sort Name	Width	Length	Break Strength	Color	Qty/Box
41011	CC12750	1/2"	3600'	750 lbs	White	2
41012	CC581000	5/8"	2800'	1000 lbs	White	2
41013	CC581200	5/8"	2500'	1200 lbs	White	2
41015	CC341350	3/4"	2150'	1350 lbs	White	2
41017	CC11850	1"	1650'	1850 lbs	White	2
41018	CC12200	1"	1650'	2200 lbs	White	2
41019	CC1143550	1-1/4"	1000'	3550 lbs	White	2

## Woven Strap



Part #	Sort Name	Width	Length	Break Strength	Color	Qty/Box
42021	CW58770	5/8"	3001'	770 lbs	Yellow	2
42025	CW342420	3/4"	1650'	2420 lbs	Yellow	2
42026	CW342700	3/4"	1650'	2700 lbs	Yellow	2
42029	CW1143250	1-1/4"	1079'	3250 lbs	Yellow	2
42032	CW1143900	1-1/4"	600'	3900 lbs	Yellow	4
42035	CW1125000	1-1/2"	600'	5000 lbs	Yellow	4



CP-1325  
Strapping  
Tool



CP-1425  
Tensioner



CP-1620  
Pusher Tensioner



CP-1850  
Sealer



CP-2450  
Cutter

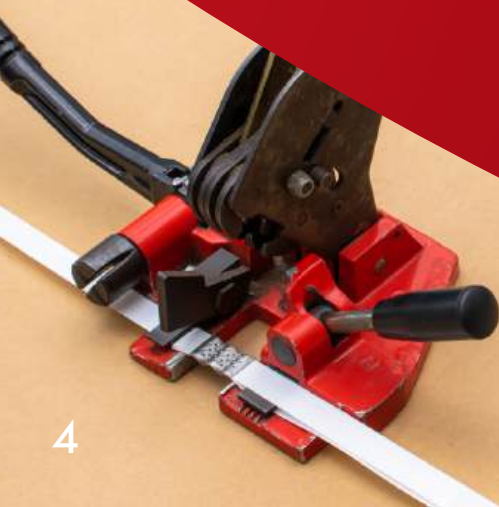

## Polyester Strap



Part #	Sort Name	Width	Gauge	Length	AAR	Coil Style	Color
40570	PET1250406HQEX	1/2"	.020	9000'	No	Embossed	Green
40575	PET12285800E	1/2"	.028	5800'	No	Embossed	Green
40572	PET1360406HQEX	1/2"	.028	7550'	No	Embossed	Green
40574	PET1670406HQEX	5/8"	.028	5300'	No	Embossed	Green
40576	PET58304000E	5/8"	.030	4000'	No	Embossed	Green
40557	PET5830GE	5/8"	.030	4600'	No	Embossed	Green
40577	PET580354BAAR	5/8"	.035	4000'	Yes	Embossed	Black
40555	PET580354KAAR	5/8"	.035	4000'	Yes	Embossed	Green
40569	PET5835GE	5/8"	.035	4000'	Yes	Embossed	Green
40558	PET5835GSAAR	5/8"	.035	4000'	Yes	Smooth	Green
40559	PET5840GEAAR	5/8"	.040	3600'	Yes	Embossed	Green
40561	PET5840GSAAR	5/8"	.040	3500'	Yes	Smooth	Green
40564	PET3440BEAAR	3/4"	.040	3000'	Yes	Embossed	Black
40562	PET3440GEAAR	3/4"	.040	3000'	Yes	Embossed	Green
40563	PET3440GSAAR	3/4"	.040	3000'	Yes	Smooth	Green
40567	PET19127GHQEXAAR	3/4"	.050	2130'	Yes	Smooth	Green
40565	PET3450GEAAR	3/4"	.050	2300'	Yes	Embossed	Green
40566	PET1050BLKSM	1"	.050	1800'	Yes	Smooth	Black
40573	PET25127GHQ1	1"	.050	1800'	No	Smooth	Green

Part #	Sort Name	Width	Gauge	Strength	Break Strength	Coil Style
43359	12020RD	1/2"	.020	Regular	1200 lbs	Oscillated
43358	58020RD	5/8"	.020	Regular	1500 lbs	Oscillated
43356	34020RD	3/4"	.020	Regular	1800 lbs	Oscillated
43362	34020HT	3/4"	.020	High Tensile	2250 lbs	Oscillated
43354	34023RD	3/4"	.023	Regular	2070 lbs	Oscillated
43364	34025HTOSC	3/4"	.025	High Tensile	2800 lbs	Oscillated
43361	34031HTOSC	3/4"	.031	High Tensile	3500 lbs	Oscillated
43357	114031HTRW	1-1/4"	.031	High Tensile	5500 lbs	Ribbon
43363	114X025RBWHT	1-1/4"	.025	High Tensile	4560 lbs	Ribbon
43365	12023RD	1/2"	.023	Regular	1380 lbs	Oscillated
43366	114029HT	1-1/4"	.029	High Tensile	5450 lbs	Ribbon
43369	34023RD-PU	3/4"	.020	Regular	2250 lbs	Punched
43370	114031HT-PU	1-1/4'	.031	High Tensile	5500 lbs	Punched

## Steel Strap



**Regular-Duty Steel Strapping** is low-carbon steel for reinforcement, bundling, palletizing, and box closure. Available in multiple finishes.

**High-Tensile Steel Strapping** provides strength and elongation for demanding loads like compressed bales and heavy coils, with more footage per coil.

# Strap Sealing

## Galvanized Buckles

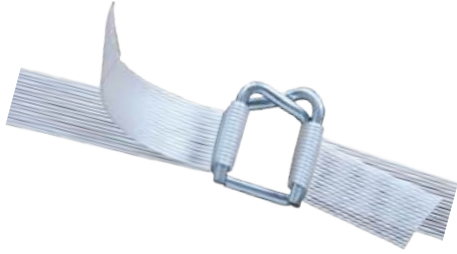

Part #	Sort Name	Width	Wire Thickness	Gauge	Qty/Box
41061	GB1233	1/2"	3.25mm	0.128	1000
41062	GB5833	5/8"	3.30mm	0.130	1000
41065	GB3440	3/4"	4.00mm	0.157	1000
41066	GB3445	3/4"	4.50mm	0.177	1000
41067	GB150	1"	5.00mm	0.197	500
41069	GB11470	1-1/4"	7.00mm	0.275	250

## Phosphated Buckles



Part #	Sort Name	Width	Wire Thickness	Gauge	Qty/Box
42072	PB5835	5/8"	3.50mm	0.138	1000
42074	PB3440	3/4"	4.00mm	0.157	1000
42075	PB3445	3/4"	4.50mm	0.177	1000
42076	PB150	1"	5.00mm	0.197	500
42077	PB11470	1-1/4"	7.00mm	0.275	250

## Serrated Seals



Part #	Sort Name	Width	Finish	Qty/Box
40556	163010KUOR	5/8"	Galvanized	1000
40571	133007KOUR	1/2"	Galvanized	1000



SC-CART16 Strapping Cart  
Part# 43371



## Banding Film

Part #	Sort Name	Width	Length	Thickness	Color	Handle
42506	SC-2-120EQ	2"	700'	120 EQ	Clear	w/ Handle
42507	SC-3-80EQ	3"	1000'	80 EQ	Clear	w/ Handle
42527	SC-3-80	3"	1000'	80 Ga	Clear	w/ Handle
42508	SC-3-90EQ	3"	1000'	90 EQ	Clear	w/ Handle
42509	SC-3-120EQ	3"	700'	120 EQ	Clear	w/ Handle
42528	SC-3-120	3"	700'	120 Ga	Clear	w/ Handle
42510	SC-5-80EQ	5"	1000'	80 EQ	Clear	w/ Handle
42511	SC-5-90EQ	5"	1000'	90 EQ	Clear	w/ Handle
42529	SC-5-90	5"	1000'	90 Ga	Clear	w/ Handle
42514	SC-5-90EQ-XCORE	5"	1000'	90 EQ	Clear	Extended Core
42533	SC-5-90-XCORE	5"	1000'	90 Ga	Clear	Extended Core

## Stretch Film

Part #	Sort Name	Width	Length	Thickness	Color
42503	SC-HCB18801500	18"	1500'	80 Ga	Clear
42504	SC-HLP18451476	17.7"	1476'	45 Ga	Clear
42505	SC-PSB15301476	15"	1476'	30 Ga	Clear
42516	SC-HCB181201000	18"	1000'	120 Ga	Clear

Part #	Sort Name	Width	Length	Thickness	Color
42500	SC-EHB20635000	20"	5000'	63 Ga	Clear
42501	SC-EHB20805000	20"	5000'	80 Ga	Clear
42502	SC-ELB20519000	20"	9000'	51 Ga	Clear
42513	SC-ETL2085000	20"	5000'	80 Ga	Blue

### Hand Stretch Film

### Machine Stretch Film

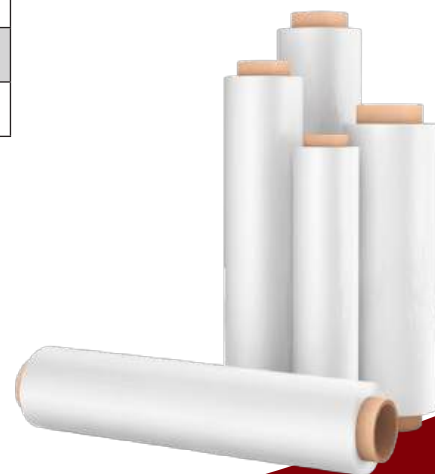

# Specialty Tape

## Filament Tape



Part #	Sort Name	Width	Length	Thickness	Color
40101	FTX-1255	12mm	55m	5.5mil	Clear
40102	FTX-3455	18mm	55m	5.5mil	Clear
40103	FTX-155	24mm	55m	5.5mil	Clear
40105	FTX255	48mm	55m	5.5mil	Clear

## Masking Tape



Part #	Sort Name	Width	Length	Thickness	Color
40081	MTX-150	24mm	55m	4.9mil	Natural
40082	MTX-250	48mm	55m	4.9mil	Natural
40083	MTX-350	72mm	55m	4.9mil	Natural
40084	MTX-450	96mm	55m	4.9mil	Natural



# Carton Sealing Tape

Part #	Sort Name	Width	Length	Thickness	Color
40085	AST-216	48mm	100m	1.6mil	Clear
40086	AST-218E	48mm	100m	1.8mil	Clear
40125	AST-218	48mm	100m	1.8mil	Clear
40127	AST-220	48mm	100m	2.12mil	Clear
40128	AST-320	72mm	100m	2.12mil	Clear
40109	AST-226	48mm	100m	2.6mil	Clear
40087	AST-326	72mm	100m	2.6mil	Clear

## Acrylic Tape



Part #	Sort Name	Width	Length	Thickness	Color
40089	HST-216	48mm	100m	1.6mil	Clear
40092	HST-316	72mm	100m	1.6mil	Clear
40093	HST-218	48mm	100m	1.8mil	Clear
40099	MHST-218	48mm	1000m	1.8mil	Clear
40094	HST-318	72mm	100m	1.8mil	Clear
40100	MHST-318	72mm	1000m	1.8mil	Clear
40112	HST-224	48mm	100m	2.4mil	Clear
40116	HST-324	72mm	100m	2.4mil	Clear

## Hot Melt Tape



Part #	Sort Name	Width	Length	Duty Level	Color
40095	WAT-350	70mm	450'	Light	Natural
40098	WAT-355	70mm	450'	Medium	Natural
40122	WAT-355W	70mm	450'	Medium	White
40119	WAT-360	70mm	450'	Heavy	Natural

## Kraft Tape



TDX-2 Tape Dispenser  
Part# 40107  
(shown on pg 8)

TDX-3 Tape Dispenser  
Part # 40108



T100  
Carton Sealer

# Protective Packaging

## Kraft Paper



Part #	Sort Name	Width	Length	Weight
43450	SC-12-30X2200	12"	1200'	30 lb
43452	SC-18-30X1200	18"	1200'	30 lb
43451	SC-18-50	18"	720'	50 lb
43453	SC-24-30X1200	24"	1200'	30 lb
43455	SC-24-40X900	24"	900'	40 lb
43454	SC-24-50X720	24"	720'	50 lb
43456	SC-28-40X900	28"	900'	40 lb
43457	SC-36-30X1200	36"	1200'	30 lb
43463	SC-36-50X1025	36"	1025'	50 lb
43461	SC-36-50X710	36"	710'	50 lb
43458	SC-36-70X167	36"	167'	70 lb
43459	SC-36-70X333	36"	333'	70 lb
43464	SC-48-40X900	48"	900'	40 lb
43465	SC-60-30X915	60"	915'	30 lb
43466	SC-68-40X555	68"	555'	40 lb

**Ask us about Automation**



PC100 Paper Pack  
w/Small Holder and Stand  
Part# 16.4464



PC1000  
w/Compact Stand  
Part# 16.4455

*\*Additional Stand Options & Accessories Available!  
See your sales representative for more information*

# Packaging Foam

Provides consistent, reliable cushioning that absorbs impact without collapsing under weight. Foam distributes pressure evenly across the surface of a product, making it especially effective at protecting edges, corners, and finished surfaces from damage during handling, stacking, and transit.

Foam Thickness	Available Widths	Length
1/32"	48" / 60" / 72"	2000'
1/16"	48" / 60" / 72"	1250'
3/32"	48" / 60" / 72"	750'
1/8"	48" / 60" / 72"	550'
3/16"	48" / 60" / 72"	350'
1/4"	48" / 60" / 72"	250'
1/2"	48" only	125'

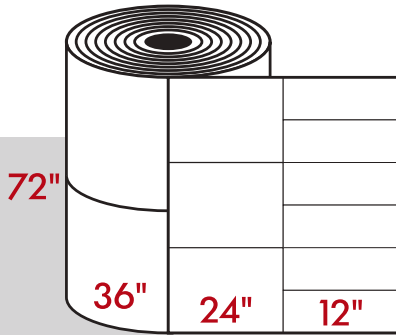

All master rolls can be slit and/or perforated to customer specifications, providing the right size for faster packing and reduced waste.

*Additional charges may apply for slitting and perforation.*

# Packing Bubbles

A lightweight, cost-effective way to protect products during handling and transit. Its air-filled bubbles absorb shock and vibration, helping reduce damage from minor impacts while keeping shipping weight and costs low. Bubble wrap is flexible and easy to use.

Bubble	Width	Length	Application
3/16"	48"	750'	Light Weight Products
5/16"	48"	375'	Medium Weight Products
1/2"	48"	250'	Heavy Weight Products

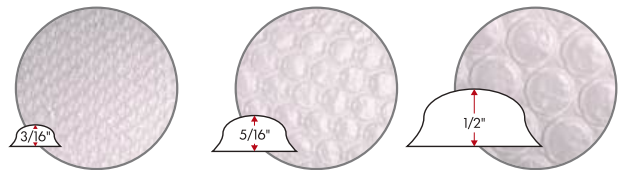
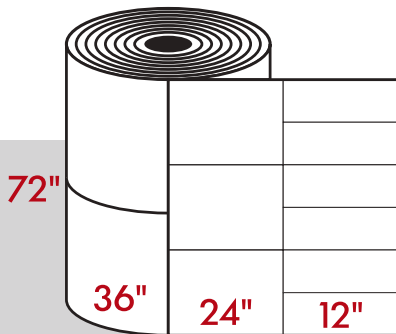

All master rolls can be slit and/or perforated to customer specifications, providing the right size for faster packing and reduced waste.

*Additional charges may apply for slitting and perforation.*



API000 w/Winder  
Part# 50.2105



Quality • Consistency • Dependability



**Challenger-Pkg.com**



*distributed by*



**SouthernCarlson**<sup>®</sup>  
Construction & Industrial Supply

1.0 4/2026

*Location Guide* →

